

# ARCH ER

# Highline

**Highline 2400**  
2400mm L x 25mm H  
Solid Brass Pendant

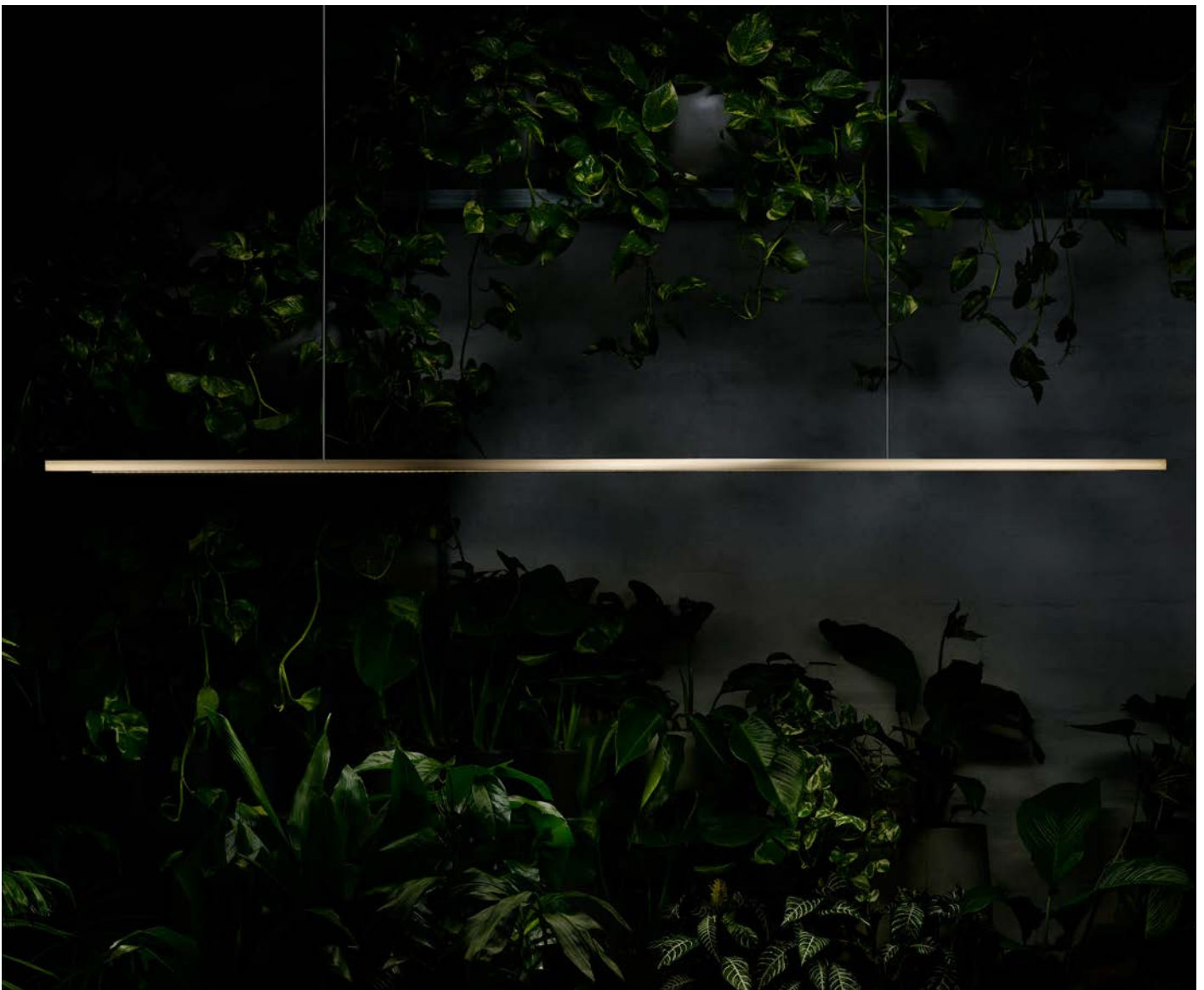

## Highline

We were building the Sawmill House and wanted something that supported a space that told its own narrative. We wanted a minimal light that encouraged the architecture, already rich with material, to speak, breathe and age gracefully.

Working with local brass millers, glass fabricators and woodworkers, the Highline is available in satin or antique patina brass, with American walnut timber and high quality LED technology. With both up and down lighting, and dimmer compatibility (switchDIM), it allows for both bright task lighting and subtle illumination.

Designed to disappear, the Highline can sit effortlessly in a variety of interior environments and be used in a variety of uses, encouraging the architecture to speak for itself.

### Dimensions (1800)

- \_ 1800mm L x 25mm solid brass profile
- \_ 2000 / 5000mm suspension cable
- \_ 900mm fixing centres

### Dimensions (2400)

- \_ 2400mm L x 25mm solid brass profile
- \_ 2000 / 5000mm suspension cable
- \_ 1200mm fixing centres

### Materials

- \_ Satin or Antique patina waxed brass
- \_ American Walnut timber detailing
- \_ Sand-blasted, fluted diffuser
- \_ Fine braided textile flex

## Details

- \_ 24V German LED strip and driver
- \_ Long Life LED up to 50,000 hours
- \_ 3000K (warm white) or 4000K (cool white)
- \_ 1800mm length has 2800 lm uplighting and 2800 lm downlighting
- \_ 2400mm length has 3900 lm uplighting and 3900 lm downlighting

Uplighting and downlighting are powered by a single driver and cannot be switched independently.

Brass is a material that ages uniquely from piece to piece, therefore colour changes over time may appear unevenly along the pendant length. This is not a fault, but a characteristic to celebrate.

## Finish Options

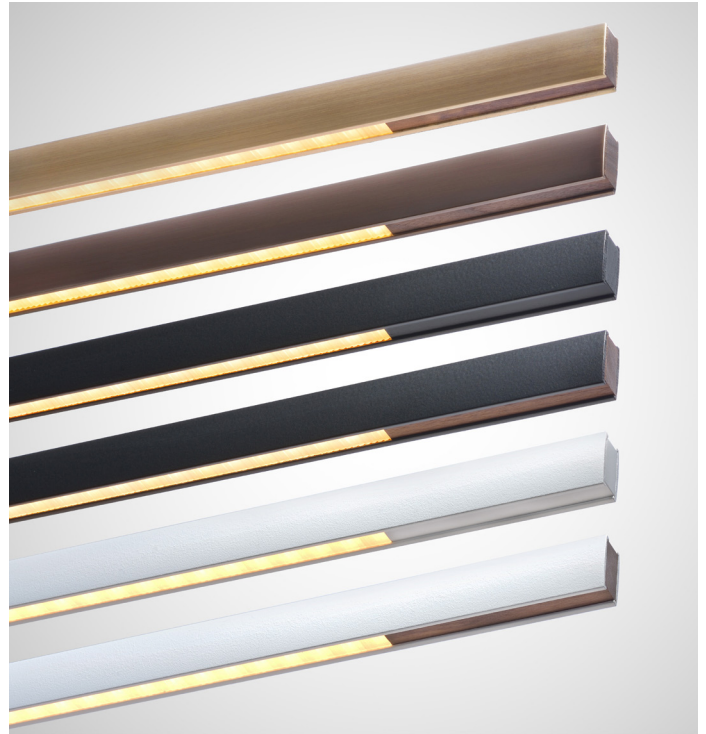

## Dimensions

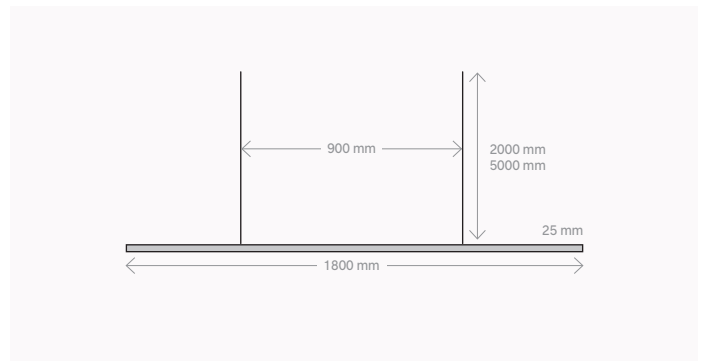

Highline 1800

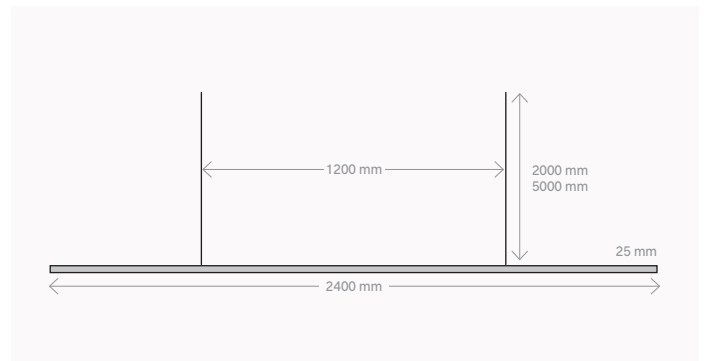

Highline 2400